

ISCAR PROMOTIONS 2026

Valid until October 31st, 2026

Indexable Tooling with a **MULTI-MASTER** Connection



Small Quad Milling Inserts for General Use

The endmill cutters with a **MULTI-MASTER** connection are suitable for mounting single-sided **HELI-4-MILL** SOMT/SOCT-04 inserts of both types for general use and fast feed milling. The cutters can be used for milling square shoulders, slots, plunging, and for efficient rough machining with high feed per tooth.

1 Use Promo Code: **T2720**

Purchase

20 inserts - SOMT 04... any assortment

Receive

Corresponding E90SO D...-MMT..-04 endmill cutter with MM connection (cutter with up to 3 pockets)

Free of Charge

YOU

MACHINING

INTELLIGENTLY?



2 Use Promo Code: **T2720**

Purchase

30 inserts - SOMT 04... any assortment

Receive

Corresponding E90SO D...-MMT..-04 endmill cutter with MM connection (cutter with 4 or more pockets)

Free of Charge

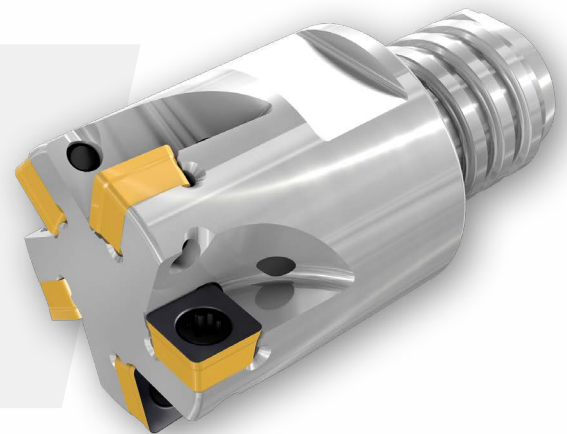

The image shown is for representational purposes.



Double-Sided Inserts with 6 Cutting Edges for **Fast Feed Machining**

HELI-DO upfeed endmills with **MULTI-MASTER** threaded adaptation for fast feed applications mount double-sided inserts with 6 cutting edges.

YOU

MACHINING

INTELLIGENTLY?

1

Use Promo Code: **T2721**

Purchase

20 inserts H600 WXCW 04... same size - any assortment

Receive

Corresponding endmill cutter FF EWX...-MMT...-04 with MM connection (cutter with up to 3 pockets)

Free of Charge

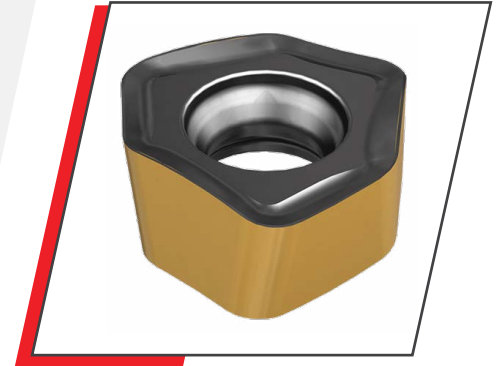

The image shown is for representational purposes.



YOU

MACHINING

INTELLIGENTLY?

Endmills with a MULTI-MASTER Threaded Adaptation, Carrying HM390 Triangular Inserts

The **MULTI-MASTER** connection expands the variety of tool configurations. Indexing is fast and convenient due to the threaded connection. Since the tool is not removed from the machine, no setup time is required for tool head replacement.

1

Use Promo Code: **T2722/ T2723**

Purchase

20 inserts - HM390 TPKR 04/ TPKT 05
same size - any assortment

Receive

Corresponding endmill HM390 ETP...-MMT..-04/05*
cutter with MM connection (cutter with up to 3 pockets)

Free of Charge

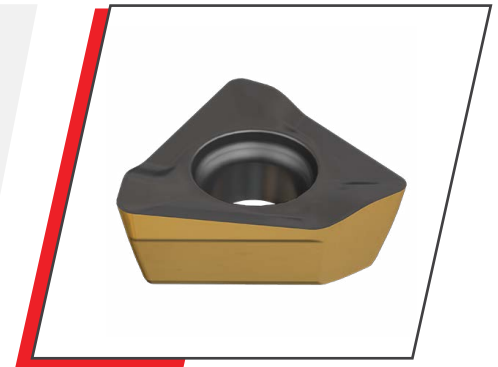

2

Use Promo Code: **T2723**

Purchase

30 inserts - HM390 TPKT 05
same size - any assortment

Receive

Corresponding endmill HM390 ETP...-MMT..-05
cutter with MM connection (cutter with 4 or more pockets)

Free of Charge

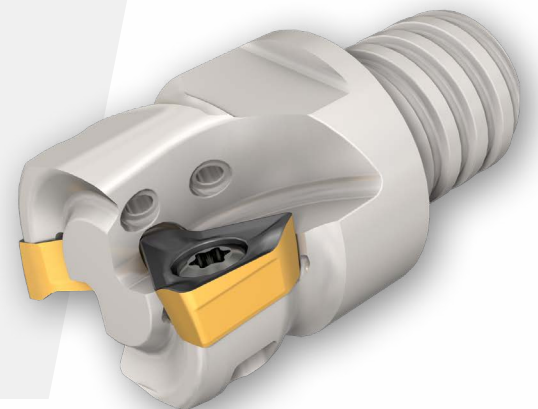

* **T2722 = 04, T2723 = 05**

The image shown is for representational purposes.



Single-Sided Small Trigon Inserts for **Fast Feed Milling**

The tools carry hexagonal, single-side inserts with 3 cutting edges and are the smallest screw clamped indexable tools for fast-feed milling.

1 Use Promo Code: **T2724**

Purchase

20 inserts -FFT3 WXMT 03... any assortment

Receive

Corresponding FFT3 EFMD...-MMT...-03 endmill cutter with MM connection (cutter with up to 3 pockets)

Free of Charge

YOU

MACHINING

INTELLIGENTLY?

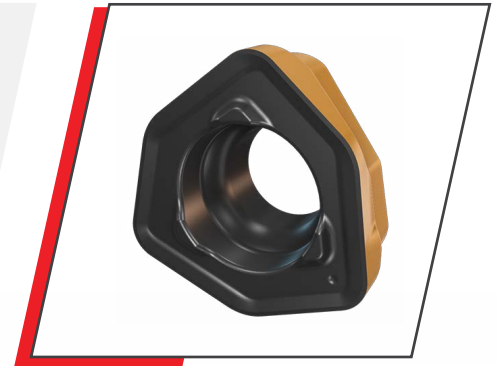

2 Use Promo Code: **T2724**

Purchase

30 inserts -FFT3 WXMT 03... any assortment

Receive

Corresponding FFT3 EFMD...-MMT...-03 endmill cutter with MM connection (cutter with 4 or more pockets)

Free of Charge

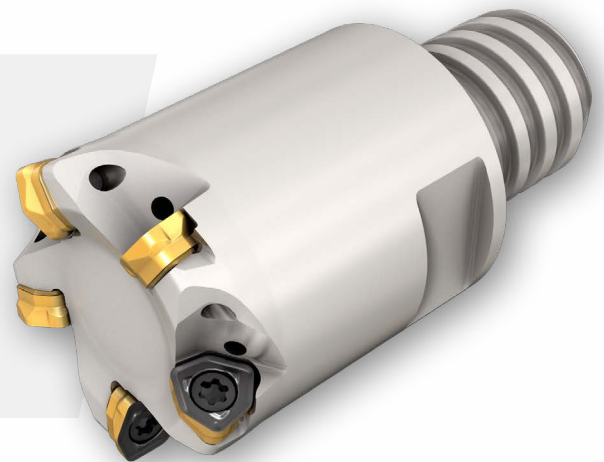

The image shown is for representational purposes.



YOU

MACHINING

INTELLIGENTLY?

Precision with Four Helical Cutting Edges

Tangentially clamped inserts with 4 helical cutting edges. The unique pocket design prevents insert pull-out and enables tools with larger core diameters compared with radially clamped inserts.

1 Use Promo Code: **T2725, T2726**

Purchase

20 inserts -T490 LNMT/HT 05/08...* any assortment

Receive

Corresponding T490 ELN D...-MMT..-05/08 endmill cutter with MM connection (cutter with up to 3 pockets)

Free of Charge

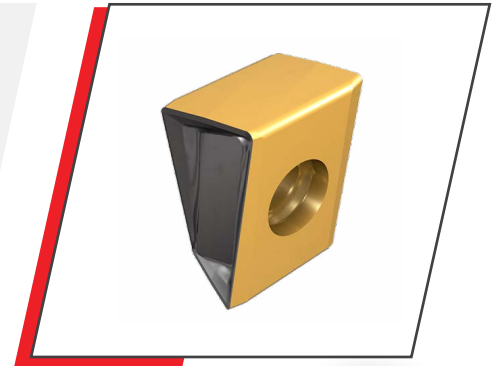

2 Use Promo Code: **T2725, T2726**

Purchase

30 inserts -T490 LNMT/HT 05/08...* any assortment

Receive

Corresponding T490 ELN D...-MMT..-05/08 endmill cutter with MM connection (cutter with 4 or more pockets)

Free of Charge

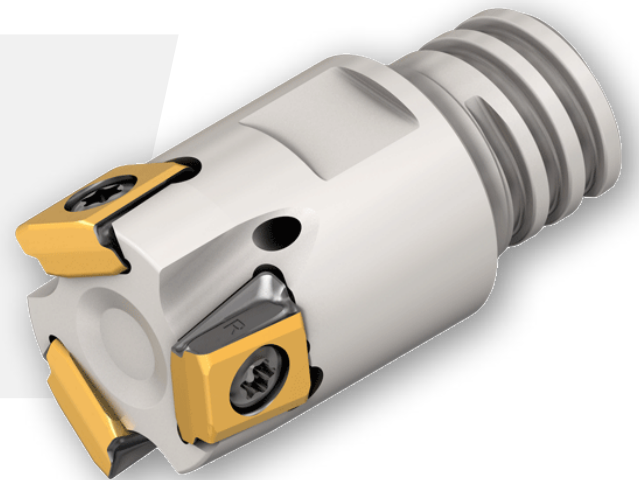

** **T2725 = 05, T2726 = 08**

The image shown is for representational purposes.



YOU

MACHINING

INTELLIGENTLY?

Highly Efficient Bone-Shaped Inserts with Four Cutting Edges for Fast, Versatile Milling

Double-sided "bone shaped" inserts with 4 cutting edges for fast feed milling. Used for small size pockets, profiling, and face milling.

1 Use Promo Code: **T2727**

Purchase

20 inserts - FFX4 XNMU 04... any assortment

Receive

Corresponding FFX4 ED...-MMT..-04 endmill cutter with MM connection (cutter with up to 3 pockets)

Free of Charge

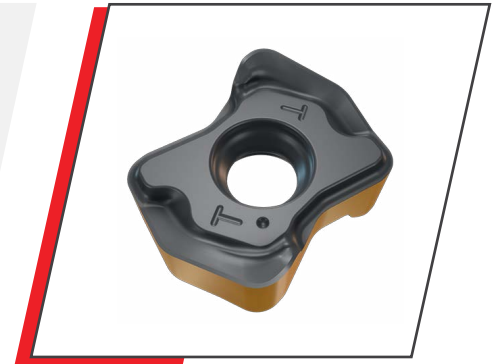

2 Use Promo Code: **T2727**

Purchase

30 inserts - FFX4 XNMU 04... any assortment

Receive

Corresponding FFX4 ED...-MMT..-04 endmill cutter with MM connection with (cutter with 4 or more pockets)

Free of Charge



The image shown is for representational purposes.

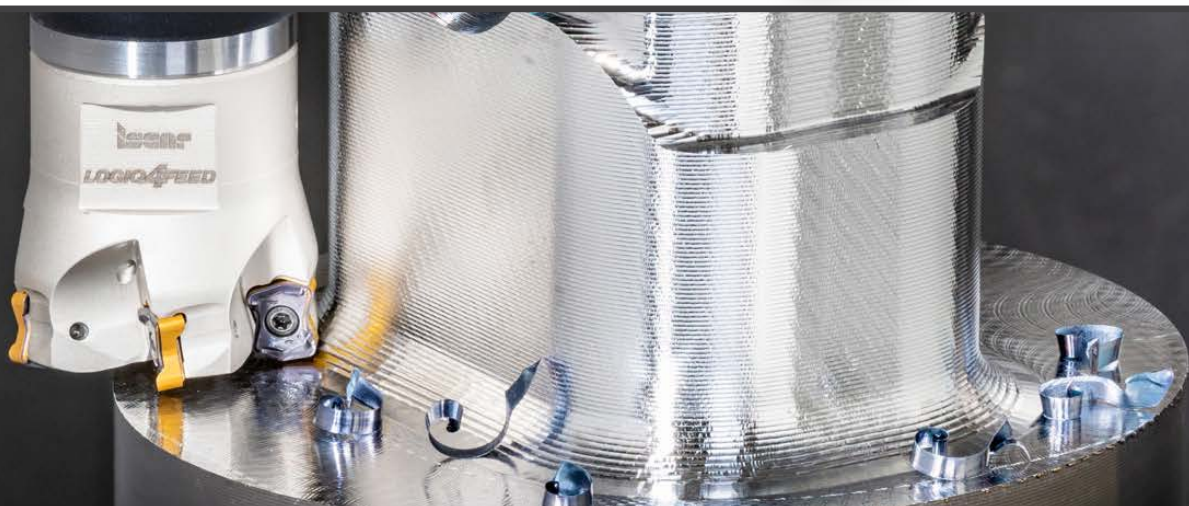

ISCAR PROMOTIONS 2026

Valid until October 31st, 2026

YOU

MACHINING

INTELLIGENTLY?

Indexable Tooling with a **MULTI-MASTER** Connection

